



[Maxim](#) > [Design Support](#) > [Technical Documents](#) > [Application Notes](#) > [Amplifier and Comparator Circuits](#) > APP 4628

Keywords: class d, class AB, power, amplifier, thermal

APPLICATION NOTE 4628

TV Audio Amplifiers—Thermal Test Considerations for Slim Systems

By: Robert Polleros, Senior Member of the Technical Staff, Applications
Mar 01, 2010

Abstract: The thermal evaluation of class D amplifiers used in TVs is still done according to the same rules for class AB amplifiers. After a detailed investigation of amplifier power dissipation with various input signals, the article proposes the use of standards that are more appropriate for class D.

A similar article appeared in three parts on the *Audio DesignLine*, April/May, 2007.

Introduction

All products with built-in audio power amplifiers, such as stereo systems, TVs, and multichannel AV receivers, have one important specification in common: the output power. This specification indicates the maximum volume that the set can deliver, and that is an important factor for many consumers.

The manufacturer must measure not only the output power, but also the thermal stability of the TV set to prove the functionality under worst-case circumstances. The standards for these tests differ across companies.

There are two kinds of amplifiers used to generate the output power, class AB and class D amplifiers. The shift to class D resulted mainly from the introduction of flat-screen (LCD and plasma) TVs, in which space was limited and heat dissipation became an issue. While the thermal test standards were developed when only class AB was used, this article investigates whether those standards are still appropriate for class D.

Maximum Output Power

Maximum output power is the amount of power that an amplifier can deliver within a specified frequency and total harmonic distortion (THD) range for a given time. For example, the power test specified by the Federal Trade Commission (FTC) requires one hour of preheating with a 1kHz sine wave at one-eighth the specified output power. Afterwards, the amplifier has to deliver the specified output power for five minutes—again, within the specified THD and frequency range. The load is usually a 4Ω or 8Ω resistor, depending on the nominal speaker impedance.

Because most TV sets do not have external speaker connections and thus no way to measure the power amplifier's output, there are no legal standards for these power measurements. Usually, the nominal power is measured with a 1kHz signal at 10% THD for at least 10 minutes.

Thermal Stability

This test proves the thermal capabilities of the whole set. The TV is placed in a chamber with the maximum specified ambient temperature, typically +40°C. Inside the set there is some temperature rise, which brings the amplifier to an even higher ambient temperature. The set is loaded with the original speakers.

Test signals of different waveforms and amplitudes can be used. This functional test checks for potential damage by evaluating temperature profiles. Testing extends over several hours, establishing the final temperature of every part. Then, several measurements are taken with infrared thermometers or thermocouples. These measurements are compared to those established in the safety standards, such as maximum PCB or junction temperatures. To pass the test for thermal stability, neither the amplifiers nor the speakers are permitted to suffer any damage.

Test Signals

The thermal stability test tries to simulate a worst-case real-life situation, which could be audio tracks found on DVDs and in a TV broadcast. However, engineers need a standardized signal which delivers the same result every time that it is used. That test should also deliver stable temperature readings once the final condition is established.

While sine waves deliver stable readings, they do not simulate program materials like music or speech, which have amplitudes that vary with time. The amplitude of the material spans the full signal range between silence and overdrive (clipping). The amplitude distribution of the program material is best described by the crest factor, which is the ratio between the peaks and average power (of the music or speech signal) expressed in dB.

Consider, for example, the following signals in **Table 1**.

Table 1. Real-Life Signals and their Matching Crest Value

Signal	Crest Factor	Description
Sine wave	3dB	Peak value of sine waves is 1.42x higher than the RMS value.
Sine wave clipped to 10% THD	1.9dB	Clipping reduces the peak by 23%, the RMS value only by 12% of their unclipped values. This reduces the ratio by 1.1dB.
Square wave	0dB	The absolute voltage is constant, therefore peaks equal the RMS voltage.
Burst signal, 50% duty cycle	3dB more than continuous signal	The RMS of 1 (on) and 0 (off) is 0.707. Reducing the RMS value by 3dB while keeping the peak value increases the ratio by 3dB.
Pink noise	~12dB	Ideal noise has Gaussian amplitude distribution and, therefore, infinite peaks and crest factor. Real implementations (noise generators, test CDs) have approximately 12dB.
Rock music	Up to 12dB	This value is found when analyzing heavy modulated commercial audio CDs.

Table 1 shows that the best artificial substitution for real-life signals is noise.

So far we considered source signals, but for thermal evaluation we are concerned with the amplifier's output signal. The signal chain also has volume and sound control, thus allowing for significant gain; it is also a fixed supply that limits the peak output voltage. Therefore, the crest factor changes if one turns up the volume. In this case the peaks are limited while the average energy still rises, so the crest factor goes **down** (it differs from the amplifier's input signal).

The lowest possible crest factor depends on the amount of distortion considered acceptable by the customer and the maximum gain settings of the set. The ideal worst-case test signal would have the lowest crest factor found in any consumer application.

Speaker manufacturers have been investigating suitable test signals. Their speakers have to process the amplifier signal without damage or serious distortion. Most manufacturers have settled for a standard called IEC 268-5, which describes a test signal: pink noise, a mix of frequencies that are filtered (40Hz highpass, 5kHz lowpass, 2nd order) to resemble the long-term frequency distribution of music (**Figure 1**).

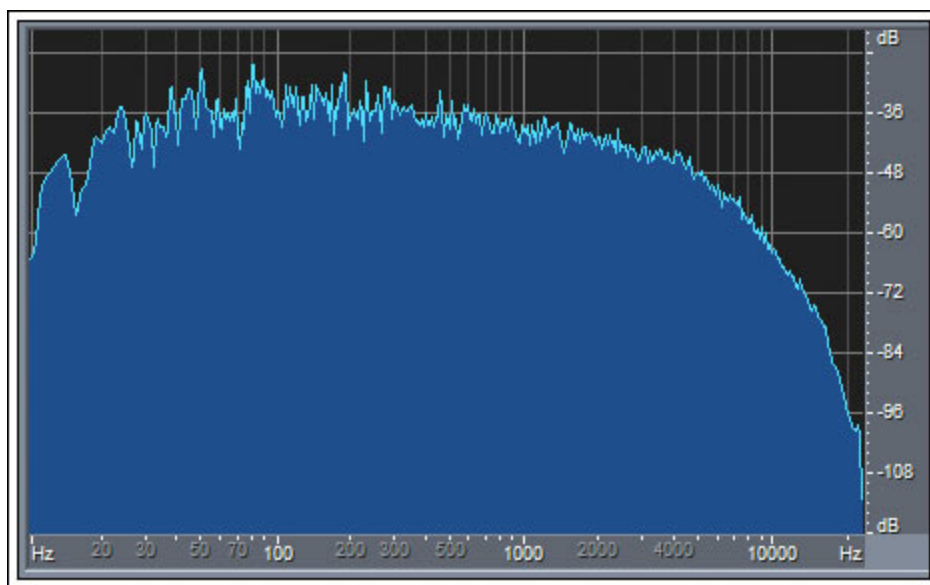

Figure 1. IEC 268-5 noise spectral density.

The IEC 268-5 test signal has a 6dB crest factor, which is considered a worst-case specification. The average power that the speaker can handle using this signal is called the "continuous power" specification. Most manufacturers, however, publish the "program power," which is 3dB higher and measured with an intermittent signal (one minute on, one minute off, etc.). So speakers can handle clipped signals with a 9dB crest factor.

The peak power, which is referred to by the crest factor, is the peak output power delivered by the amplifier. The rated output power of the amplifier is measured with sine waves, which are 3dB. Therefore, the long-term power handling of the speakers is 6dB less than the rated amplifier power. The worst-case long-term test signal for the whole set is an IEC 268 noise spec whose RMS power is 9dB below the peak output or 6dB below the largest sine wave, which is the maximum output power from the sine wave test.

When designing the thermal capability of the amplifier, there is no reason to request more than the speakers can handle. Integrated amplifiers usually have thermal protection, so the worst thing that happens is muting, which is automatically reset after the amplifier cools down again. Since speaker overload results in permanent damage, setting the amplifier's thermal limit to a lower level can actually

be a way to protect the speaker.

Amplifier Classes

TVs use either of two types of audio amplifiers: class AB and class D. We want to analyze how these types perform in the previously mentioned tests. Class AB amplifiers have been the low-cost workhorse solution, but they have significant power dissipation issues and thus require large heatsinks. Class D amplifiers are known for better efficiency, but that benefit comes with a downside: a higher price for the silicon of the amplifier. This price disadvantage can be compensated for, since less cooling effort (smaller or no heatsinks) will be required and smaller IC packages can be used. However, the system still has to pass the thermal test. So the test strategy is defining the cost of the amplifier.

To simplify the comparison of the two classes, let us assume that both use FET, not bipolar, output transistors. Then, the maximum output voltage for a given supply voltage (V_{CC}), load (R_L), and R_{DSON} (the resistance of the fully conducting output transistors) is the same for both classes, as is the maximum output power.

Let us also assume a bridge-tied-load (BTL) output: the output current flows through two transistors and R_{DSON} counts twice (**Figure 2**).

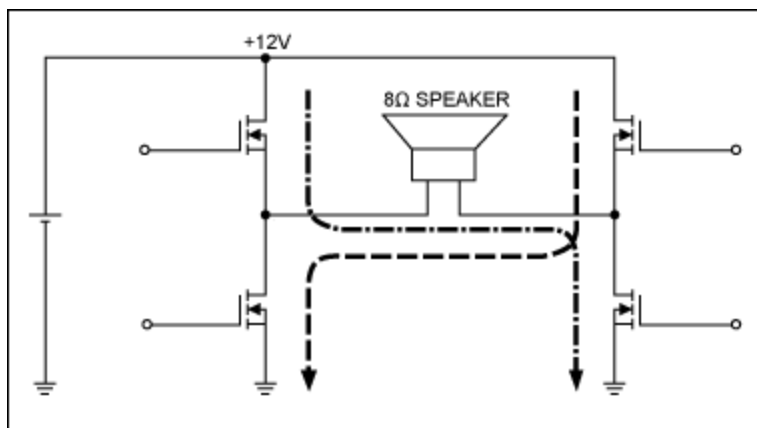

Figure 2. BTL amplifier output stage.

Dissipation is quite different for each amplifier class. We start with the DC analysis for an output voltage, U_a , (giving the output power $P = U_a^2/R_L$):

Class AB

$$D_{ab} = [(U_a/R_L) \times (V_{CC} - U_a)] + I_Q \times V_{CC}$$

Dissipation equals the output current multiplied by the voltage drop on the output transistors.

Class D

$$D_d = (U_a/R_L)^2 \times 2 \times R_{DSON} + I_Q \times V_{CC}$$

Dissipation consists mainly of resistive losses, $(\text{output current})^2 \times R$.

Both amplifier classes have a constant factor: $I_Q \times V_{CC}$, where I_Q is the quiescent current. Class AB amplifiers use this current to reduce crossover distortions, but this current represents switching losses for

Class D amplifiers. This current is of similar magnitude for both classes.

Further analysis can be done by simulation. We choose a common TV application that uses a 12V supply and 8Ω speakers, and we will use the following numbers for parameters:

$$\begin{aligned} V_{CC} &= 12V \\ R_I &= 8\Omega \\ R_{DSON} &= 0.3\Omega \\ I_Q &= 0.02A \end{aligned}$$

First we must determine efficiency, which is calculated with the following equation:

$$\text{Efficiency} = \frac{\text{OutputPower}}{\text{InputPower}} = \frac{\text{OutputPower}}{\text{OutputPower} + \text{Dissipation}}$$

Figure 3 illustrates the efficiency of the sine wave input and also shows the distortion of the output signal. That distortion is caused by clipping, and the clipping, in turn, is due to the limited supply voltage.

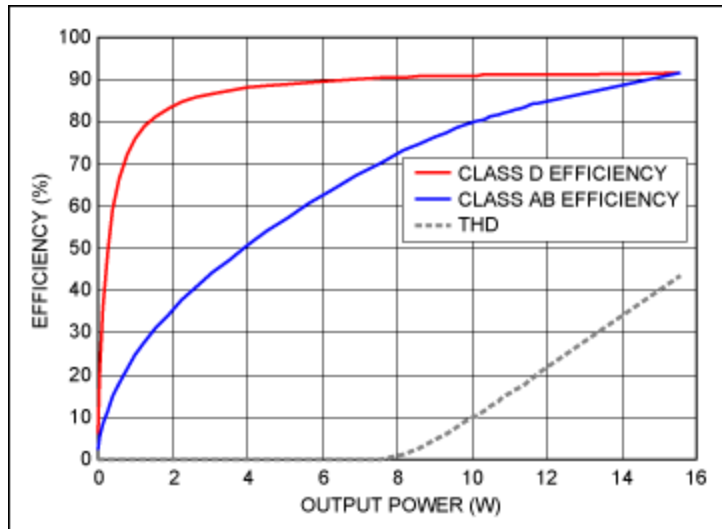

Figure 3. Efficiency vs. output power.

The following equation is used to calculate the maximum output-voltage swing:

$$U_{pk} = V_{CC} \times \frac{R_I}{R_I + 2 \times R_{DSON}} = 11.16V$$

At 10% THD the output power is 10W, which is the specified maximum output power of the system.

As the graph in Figure 3 indicates, class D amplifiers offer much better efficiency versus output power than class AB amplifiers. There are only two points in the graph at which class D amplifiers do not outperform class AB amplifiers:

- Zero input: both amplifiers consume only quiescent power, which is assumed to be the same.
- Infinite overload: produces a square-wave output, which is always saturated, even with class AB. At this point, both amplifiers have the same efficiency, dissipation, output power (15.56W), and distortion (43.5%).

While efficiency figures are important for battery-operated systems, designers of mains powered equipment are more interested in the dissipation characteristics of amplifiers. **Figure 4** shows the

dissipation that each amplifier class creates with a sine wave input and varying gain.

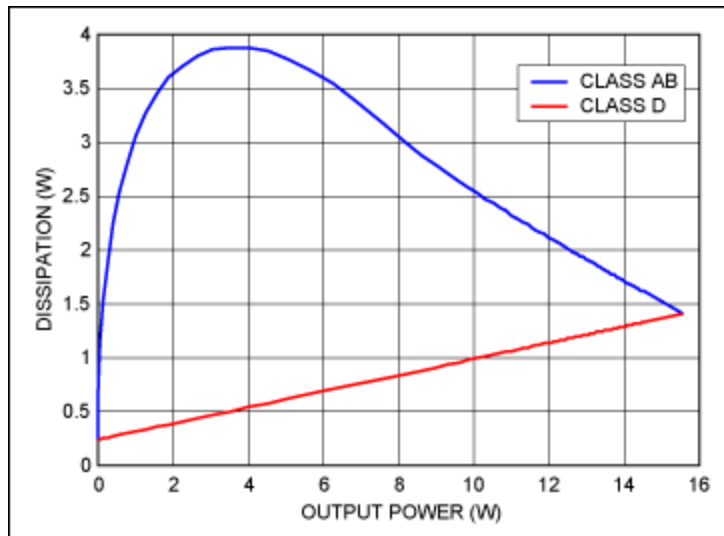

Figure 4. Dissipation vs. output power.

At the rated power of 10W, the dissipation is 2.53W for class AB and only 0.994W for class D amplifiers. At lower inputs class D dissipation decreases, while it increases for class AB.

How does this relate to real life when the amplifier is used for music or speech? This scenario is best simulated using noise signals which have an amplitude distribution similar to music and lead to consistent results.

To compare the results to real listening situations and to the speakers' power-handling capabilities, we must change the x-axis from power to crest factor. The crest factor gives the relationship between average output power and the peak power of this system, which is 15.56W.

Ideal noise sources have infinite crest factors; their amplitude distribution follows a "normal distribution" with well-defined variance but no limit to the peak voltage. This distribution changes when we route the signal through our simulated amplifier—the output signal is limited by the supply rails. The average (RMS) voltage changes as one changes the gain of the system. Increasing the RMS voltage decreases the crest factor, as the peak reference is constant.

While clipping rarely occurs at high crest factors, it occurs more frequently as the gain is increased. **Figure 5** shows noise with a 3dB crest factor, where the output signal is heavily clipped.

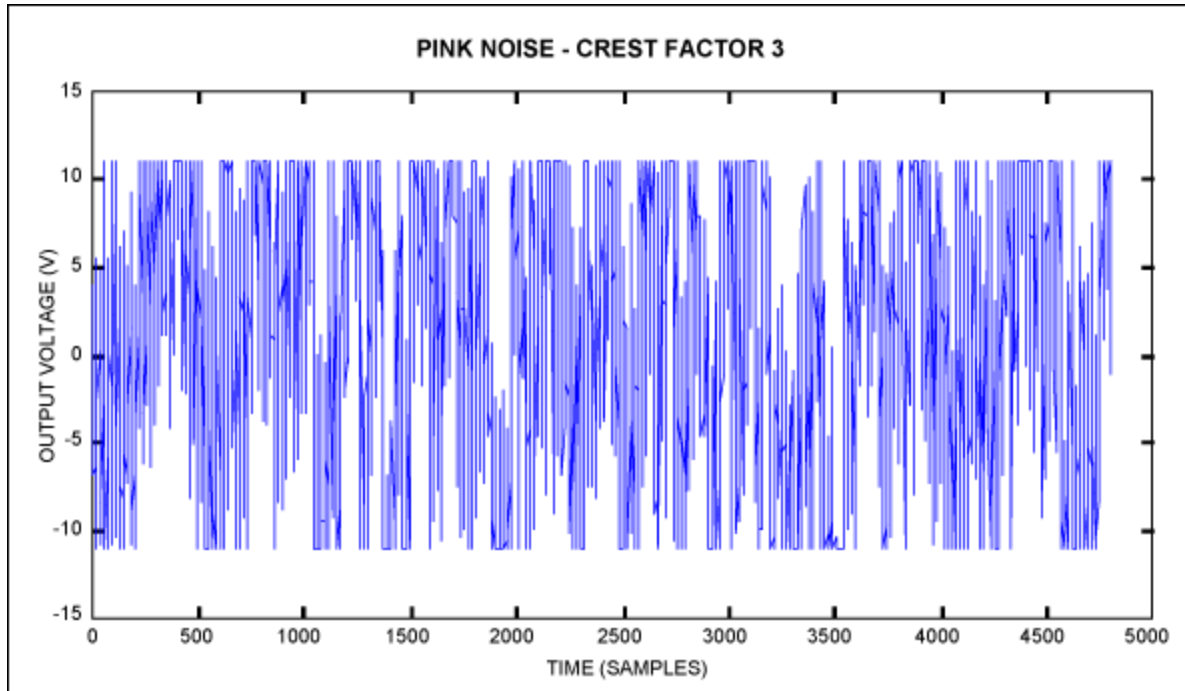

Figure 5. Amplifier output voltage with 3dB noise.

For this simulation we are not concerned with the "color" of the noise; real tests, however, should use the IEC 268-5 signal because some amplifiers have reduced efficiency at high frequencies.

As we change the gain, we can calculate the dissipation for all possible crest values (see Figure 5).

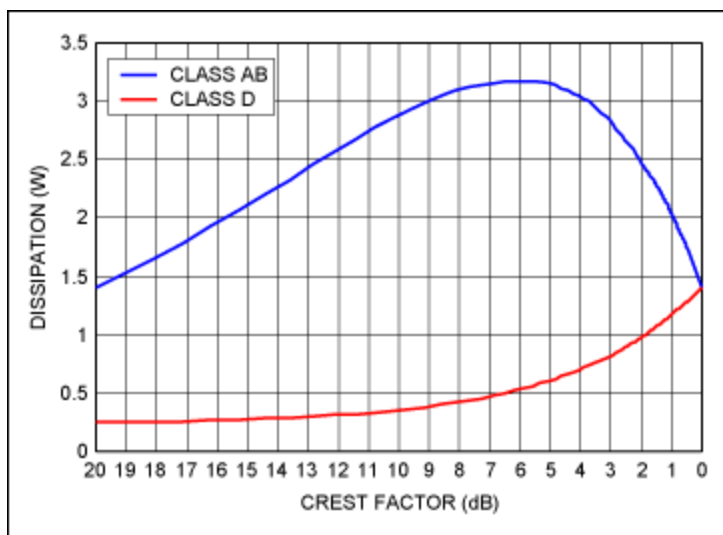

Figure 6. Dissipation vs. power density (crest factor).

Figure 6 shows high output power to the right, now expressed as low crest factors.

- At 15dB to 12dB even very dense music gets heavily clipped, which would lead most listeners to turn the volume down.
- 9dB is considered the worst allowable crest factor by speaker manufacturers.
- 0dB produces a full-scale square wave output.

At 9dB, which would be the most reasonable point for thermal evaluation, the dissipation is:

- 3.05W for class AB
- 0.388W for class D.

The ratio in this case is $3.05/0.388 = 7.86$, while for the output power test it was only $2.53/0.994 = 2.55$.

This simulation has important implications.

For a class AB amplifier, the thermal challenge is to pass the noise test. Once the amplifier is designed to absorb those 3.05W per channel, there are no more thermal problems at the rated output power with 2.53W dissipation per channel. The rated output power can be delivered forever.

Since the power dissipation is similar in both tests, it became common practice to use the sine waves for both the output power and the thermal test. Of course, a test using sine waves is slightly easier to set up, but it leads to less dissipation than the recommended noise test.

In other words, using sine waves for thermal evaluation leads to class AB amplifiers with less power handling than speakers of the same wattage.

For class D amplifiers, the situation is reversed. The noise test creates a 0.388W dissipation. Meanwhile, at rated output power 1W is dissipated, which is 2.56 times more. So it makes quite some difference which signal is used for thermal evaluation.

Consequently, using sine waves for thermal evaluation of class D amplifiers leads to largely oversized systems, which drives up the cost. In summary for class D amplifiers:

- IC suppliers need bigger die sizes to reduce $R_{\text{DS(ON)}}$, one of the main contributors to efficiency.
- Class D amplifiers need bigger packages to have a low thermal resistance between the junction and PCB or heatsink.
- Manufacturers need to provide either small heatsinks or multilayered PCBs to realize low $R_{\theta\text{JA}}$ values, which is the junction-to-ambient thermal resistance.
- If the PCB is used for heatsinking, careful layout is needed to have large uninterrupted areas of copper. The copper is used for thermal transfer and there should also be good thermal connections between the layers by using multiple vias.

Burn-In Test

Sometimes an even more severe test, called the burn-in test, is used for thermal evaluation. This test applies the maximum voltage available from the sound processor at the input of the power amp, leading to a square-wave-like output signal. This test dissipates up to 1.41W per channel in the example amplifier used in this article, and there remains no benefit compared to a class AB amp. To pass this test class D amplifiers require 3.6 times better cooling compared to the noise test.

Conclusion

The transition from CRTs to flat-screen TVs has led to the need for smaller amplifiers with less heat dissipation, so class D amplifiers were introduced. Even when using the traditional sine-wave tests the new designs reduced the heat by a factor of 2.5x, but there is yet another 2.6x factor in reduction when switching to noise signals for thermal evaluation.

Engineers had to cope with new challenges: solving EMI, designing output filters, and dealing with small amplifier packages with exposed pads for cooling. Now it is time to rethink the test methods to unveil the

full potential of cost savings involved with class D.

This is the recommended method:

- Check output power in burst mode. Apply full-power sine waves only as long as needed to obtain THD values.
- Check thermal capability with noise signals or the worst-case practical application (speech or music). This should be accompanied by gain settings that limit amplifier clipping so that even full-volume settings produce acceptable sound.

Related Parts

MAX9736	Mono/Stereo High-Power Class D Amplifier	Free Samples
MAX9744	20W Stereo Class D Speaker Amplifier with Volume Control	Free Samples

More Information

For Technical Support: <http://www.maximintegrated.com/support>

For Samples: <http://www.maximintegrated.com/samples>

Other Questions and Comments: <http://www.maximintegrated.com/contact>

Application Note 4628: <http://www.maximintegrated.com/an4628>

APPLICATION NOTE 4628, AN4628, AN 4628, APP4628, Appnote4628, Appnote 4628

Copyright © by Maxim Integrated Products

Additional Legal Notices: <http://www.maximintegrated.com/legal>