



TAI-SAW TECHNOLOGY CO., LTD.

No. 3, Industrial 2nd Rd., Ping-Chen Industrial District,
Taoyuan, 324, Taiwan, R.O.C.

TEL: 886-3-4690038 FAX: 886-3-4697532

E-mail: tstsales@mail.taisaw.com Web: www.taisaw.com

Product Specifications Approval Sheet

Product Description: SAW Rx Filter 2140MHz LTE Band 1 SMD 1109

TST Part No.: TA1845D

Customer Part No.: _____

Customer signature required
Company: _____
Division: _____
Approved by : _____
Date: _____

Checked by: _____ Michael Yang *Michael*

Approved by: _____ Andy Yu *Andy Yu*

Date: _____ 2021/04/09

1. Customer signed back is required before TST can proceed with sample build and receive orders.
2. Orders received without customer signed back will be regarded as agreement on the specifications.
3. Any specifications changes must be approved upon by both parties and a new revision of specifications shall be released to reflect the change



TAI-SAW TECHNOLOGY CO., LTD.

No. 3, Industrial 2nd Rd., Ping-Chen Industrial District,
Taoyuan, 324, Taiwan, R.O.C.

TEL: 886-3-4690038 FAX: 886-3-4697532

E-mail: tstsales@mail.taisaw.com Web: www.taisaw.com

SAW Rx Filter 2140MHz LTE Band 1 SMD 1109

MODEL NO.: TA1845D

REV. NO.:5.0

A. MAXIMUM RATING:

1. Operating temperature range: -30 °C to +85 °C
2. Storage temperature range: -40 °C to +85 °C
3. Maximum Input Power: +10 dBm
4. Maximum DC Voltage: +/-0 V
5. Moisture Sensitivity Level: Level 3
6. ESD 50V(MM) 100V(HBM)



Electrostatic Sensitive Device (ESD)

B. ELECTRICAL CHARACTERISTICS:

Terminating source impedance: $Z_s = 50 \Omega$ (Single-ended)

Terminating load impedance: $Z_L = 50 \Omega$ (Single-ended)

Parameters Description		Unit	Minimum	Typical	Maximum	
Center Frequency		MHz	-	2140	-	
Insertion Loss	2110~2170 MHz	dB	-	1.9	2.5	
	2110~2155 MHz	dB	-	1.9	2.5	
Amplitude Ripple	2110~2170 MHz	dBp-p	-	0.6	1.5	
	2110~2155 MHz	dBp-p	-	0.6	1.5	
VSWR	Input	2110~2170 MHz	-	-	1.8	2.3
	Output	2110~2155 MHz	-	-	1.8	2.3
Attenuation:						
50-1710 MHz		dB	35	40	-	
1710-1755 MHz		dB	40	42	-	
1920-1980 MHz		dB	42	45	-	
4220-4340 MHz		dB	30	42	-	

Notes : (1) No Matching Network ..

C. FREQUENCY CHARACTERISTICS:

Frequency Response

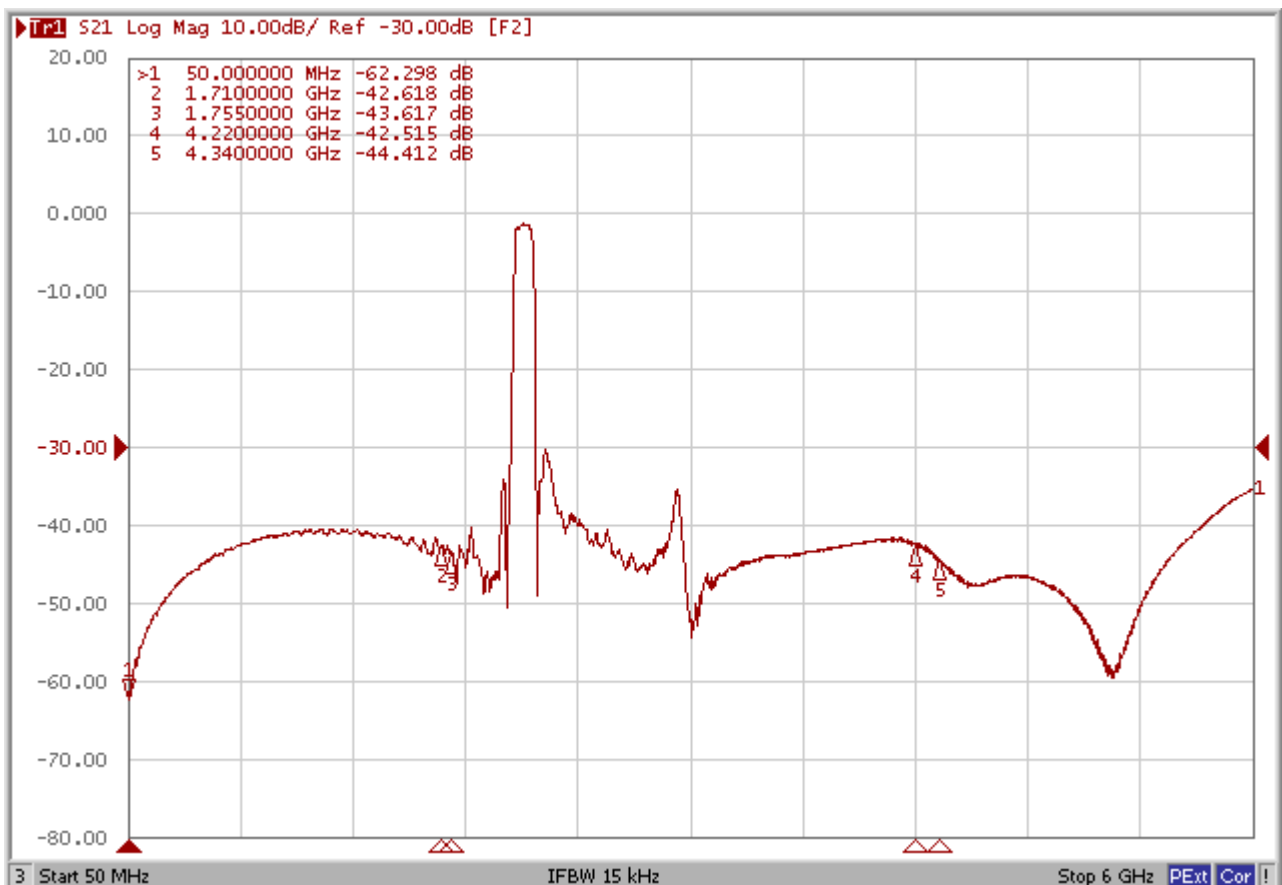
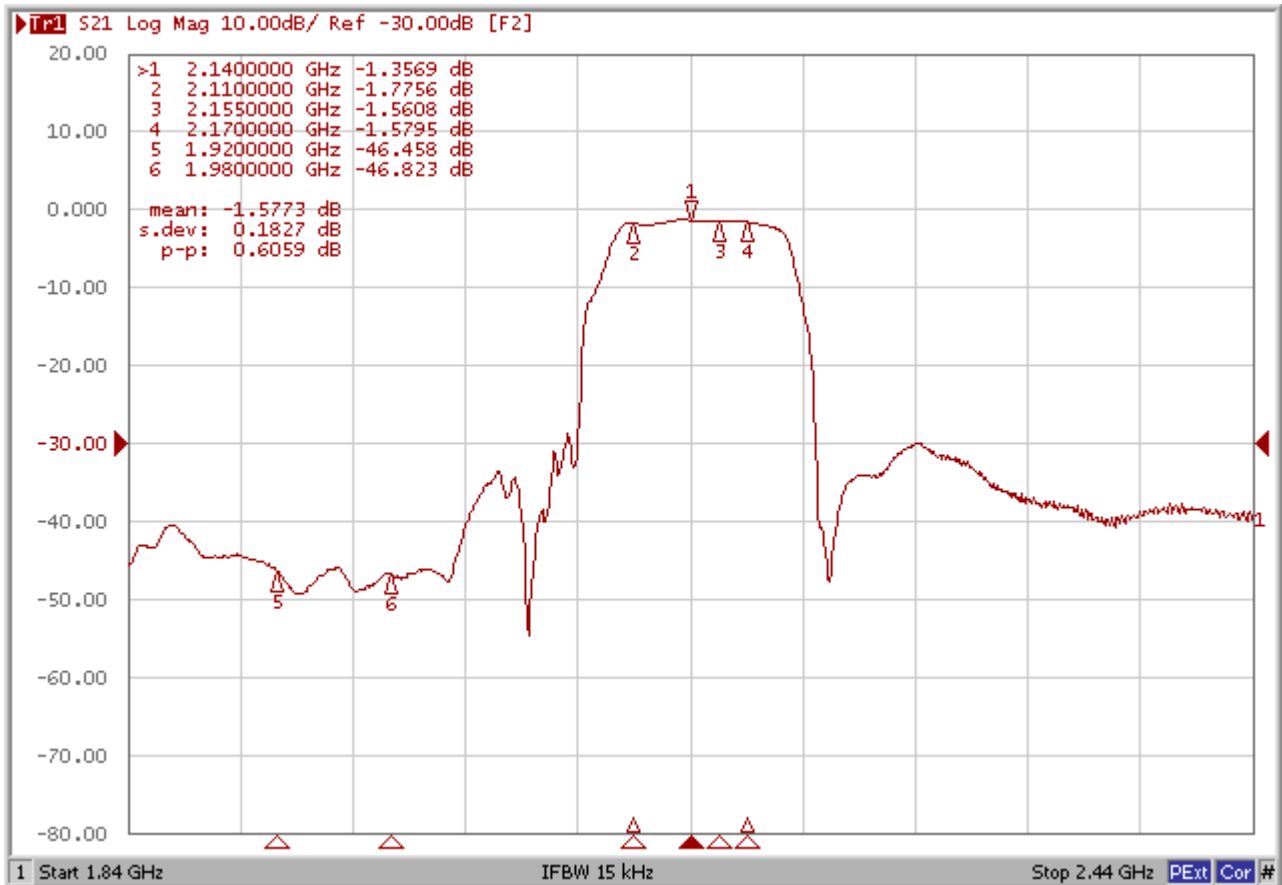

VSWR

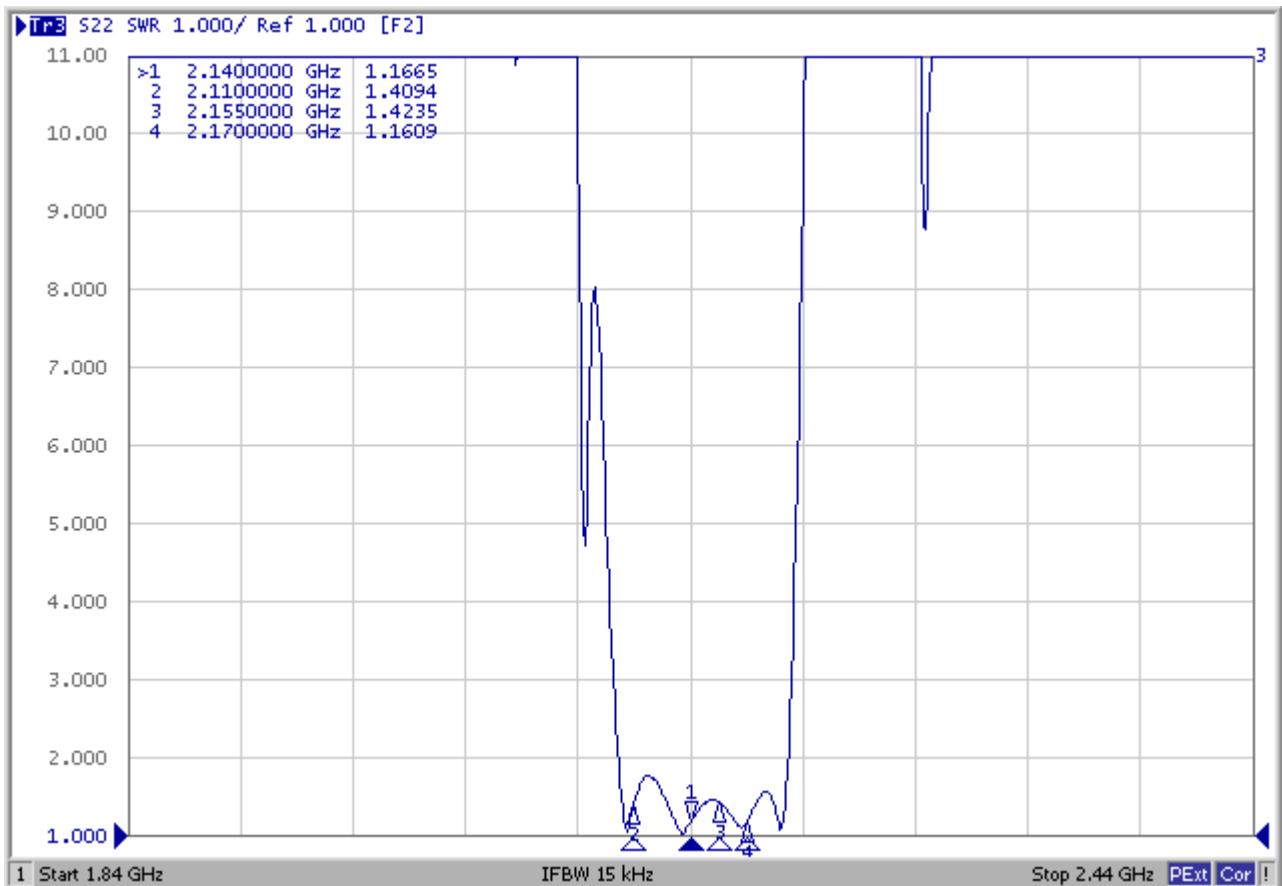
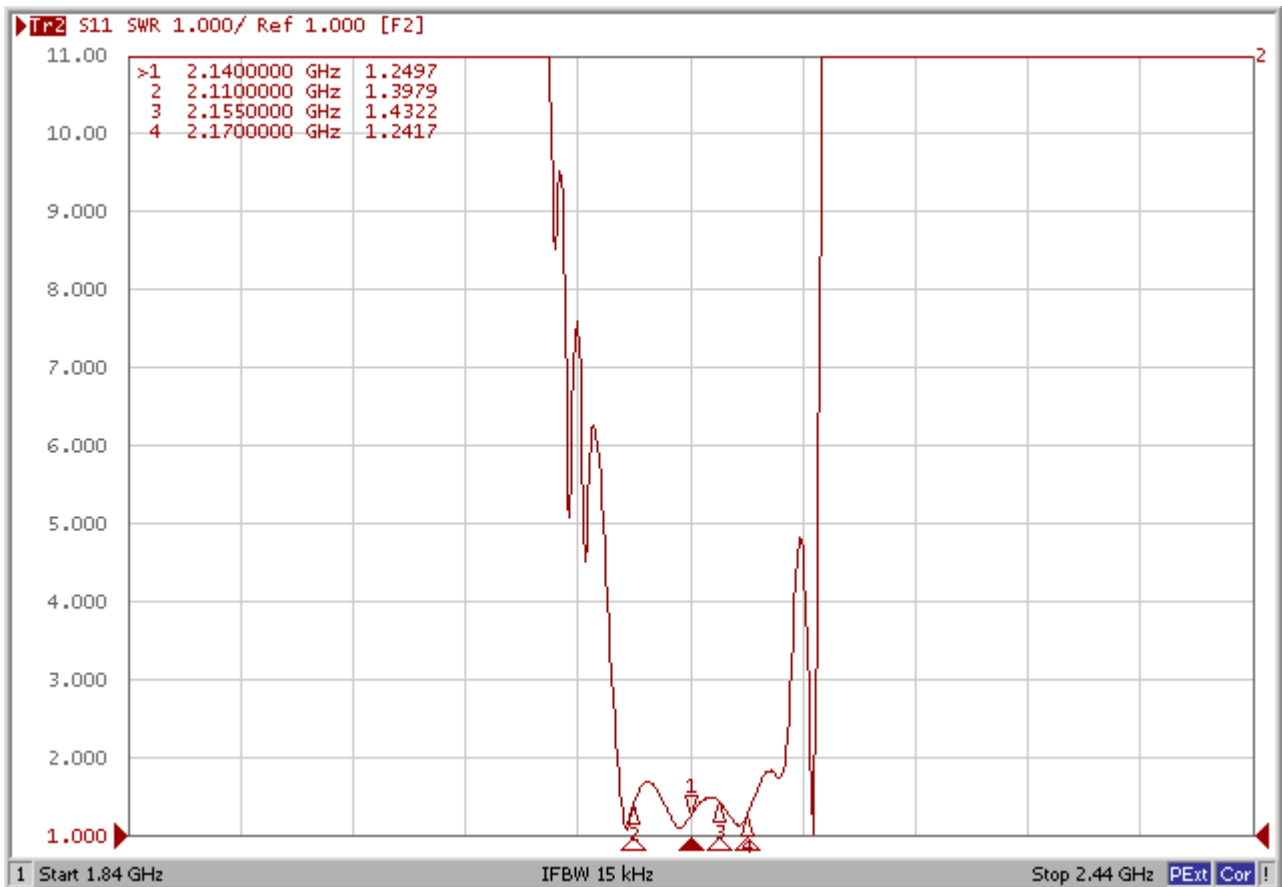

Smith Chart

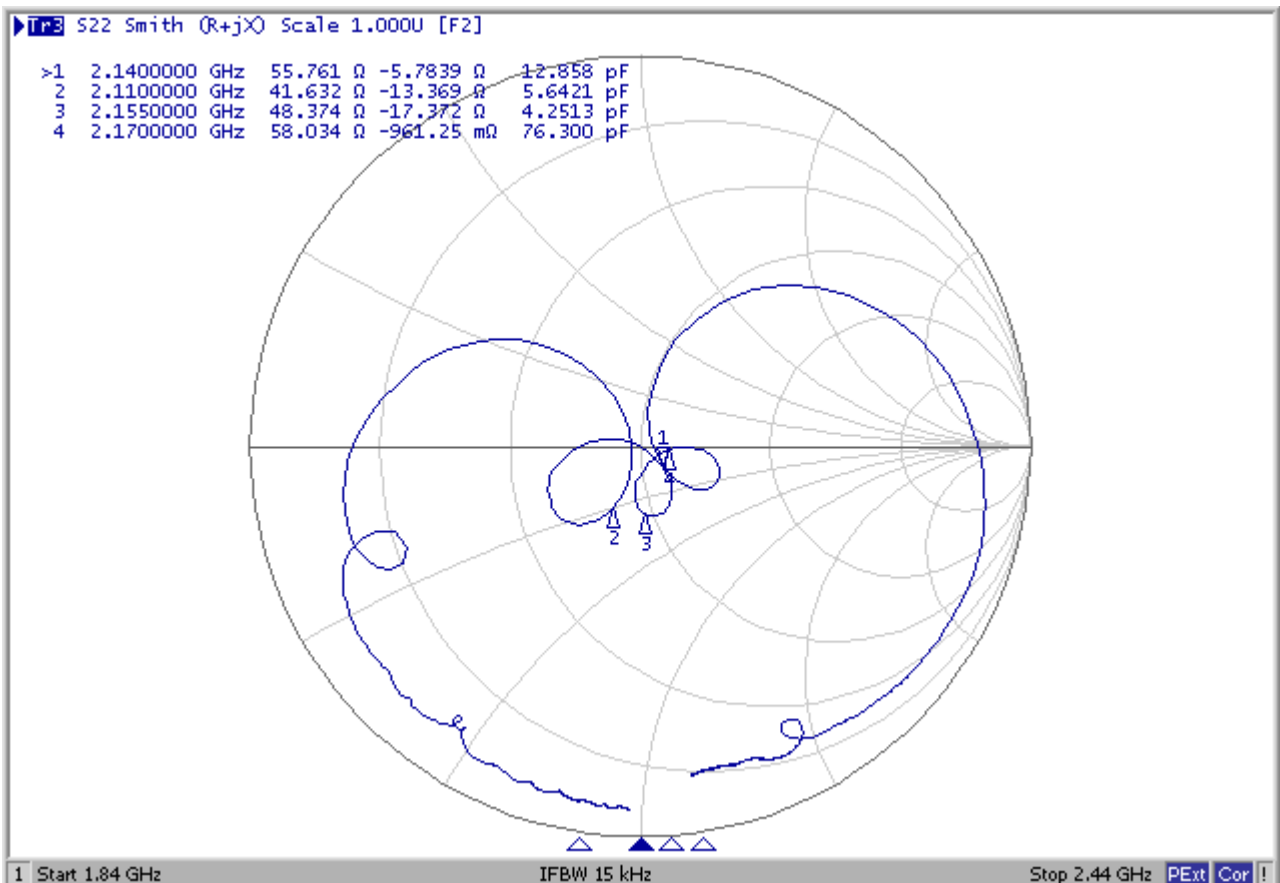
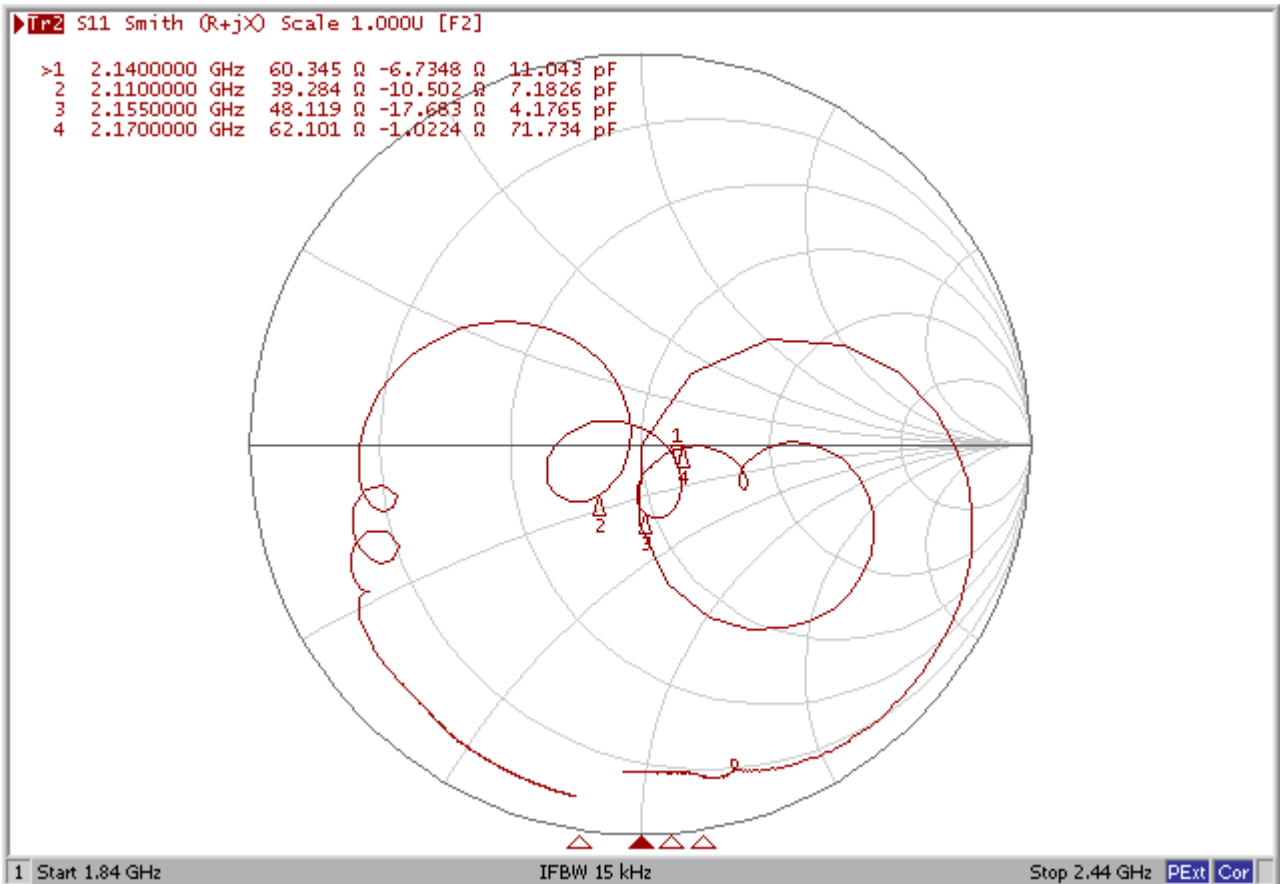

D. OUTLINE DRAWING:

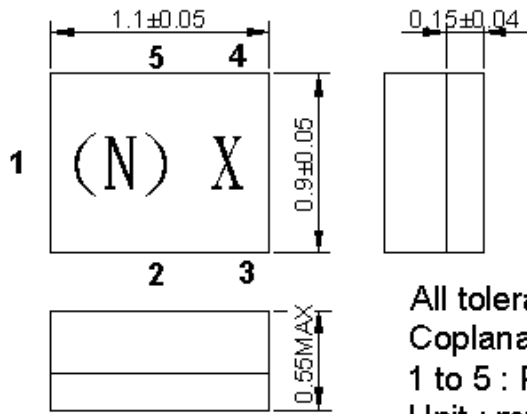

All tolerances are +/-0.05 mm unless otherwise specified
Coplanarity : 0.1 mm max.

1 to 5 : Pin No.

Unit : mm

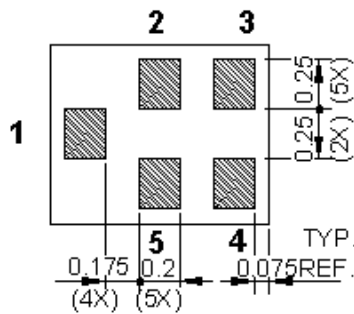

Pin No.	Symbol	Function
1	IN	Input
2	GND	Ground
3	GND	Ground
4	OUT	Output
5	GND	Ground

Marking Descriptions:

(N) : Series Number

X : Year/Month Code (Follow the table)(每 8 年循環)

YEAR/Month	1	2	3	4	5	6	7	8	9	10	11	12
2013 / 2021	A	B	C	D	E	F	G	H	J	K	L	M
2014 / 2022	N	P	Q	R	S	T	U	V	W	X	Y	Z
2015 / 2023	a	b	c	d	e	f	g	h	j	k	l	m
2016 / 2024	n	p	q	r	s	t	u	v	w	x	y	z
2017 / 2025	<u>A</u>	<u>B</u>	<u>C</u>	<u>D</u>	<u>E</u>	<u>F</u>	<u>G</u>	<u>H</u>	<u>J</u>	<u>K</u>	<u>L</u>	<u>M</u>
2018 / 2026	<u>N</u>	<u>P</u>	<u>Q</u>	<u>R</u>	<u>S</u>	<u>T</u>	<u>U</u>	<u>V</u>	<u>W</u>	<u>X</u>	<u>Y</u>	<u>Z</u>
2019 / 2027	<u>a</u>	<u>b</u>	<u>c</u>	<u>d</u>	<u>e</u>	<u>f</u>	<u>g</u>	<u>h</u>	<u>j</u>	<u>k</u>	<u>l</u>	<u>m</u>
2020 / 2028	<u>n</u>	<u>p</u>	<u>q</u>	<u>r</u>	<u>s</u>	<u>t</u>	<u>u</u>	<u>v</u>	<u>w</u>	<u>x</u>	<u>y</u>	<u>z</u>

E. MEASUREMENT CIRCUIT:

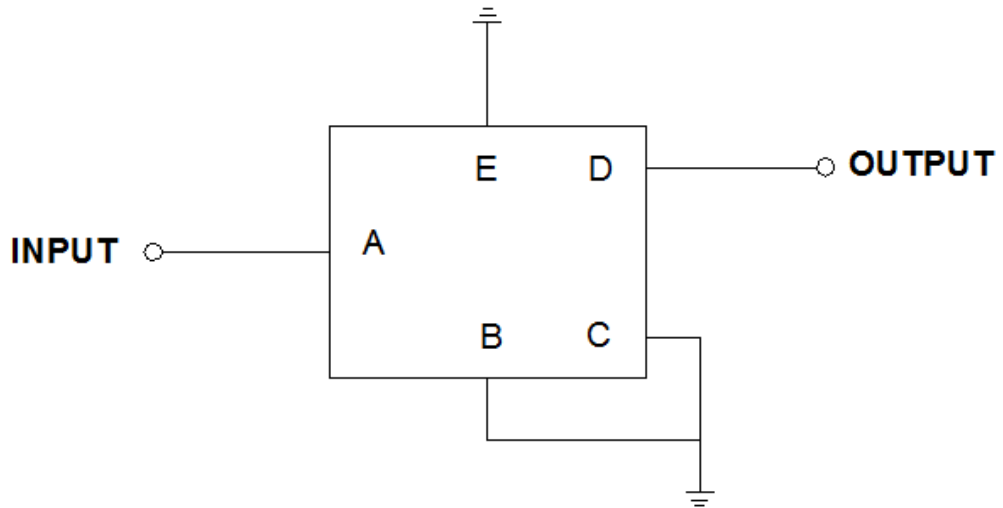

Source & Load Impedance: 50 Ω

F. PCB Footprint :

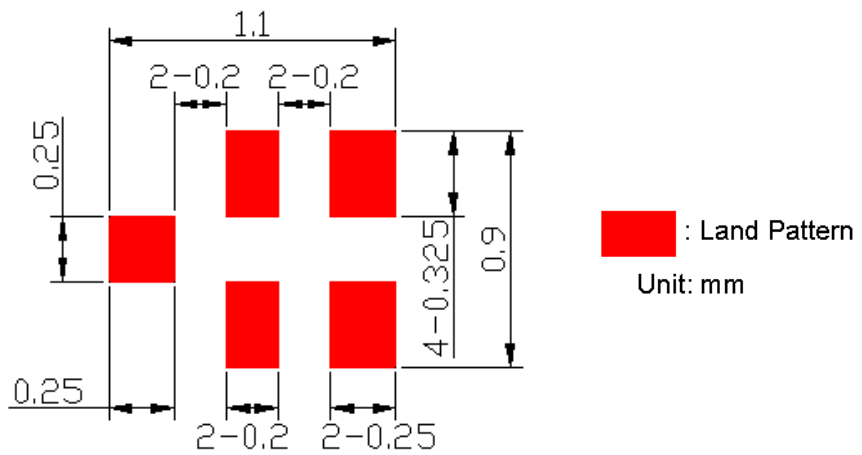

G. PACKING:

1. REEL DIMENSION

(Please refer to FR-75D10 for packing quantity)

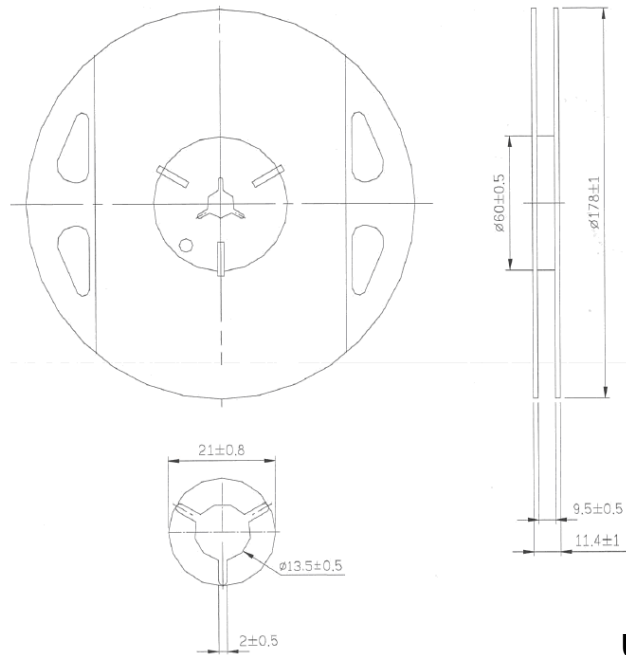

Unit: mm

2. TAPE DIMENSION

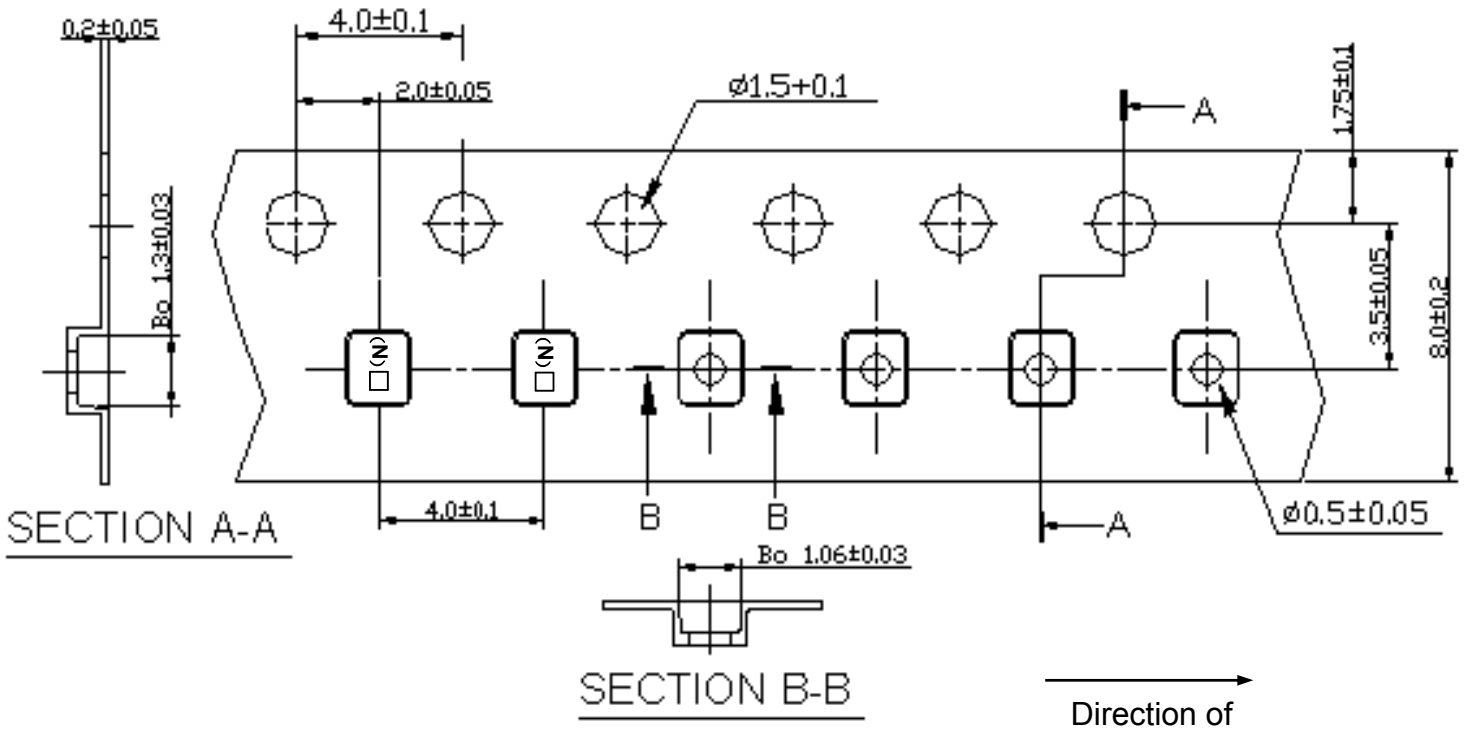

H. RECOMMENDED REFLOW PROFILE:

1. Preheating shall be fixed at 150~180°C for 60~90 seconds.
2. Ascending time to preheating temperature 150°C shall be 30 seconds min.
3. Heating shall be fixed at 220°C for 50~80 seconds and at 260°C +0/-5°C peak (20~40sec).
4. Time: 2 times.

