

### General Description

The MIC5020 low-side MOSFET driver is designed to operate at frequencies greater than 100kHz (5kHz PWM for 2% to 100% duty cycle) and is an ideal choice for high-speed applications such as motor control, SMPS (switch mode power supplies), and applications using IGBTs. The MIC5020 can also operate as a circuit breaker with or without automatic retry. The MIC5020's maximum supply voltage lends itself to control applications using up to 50V. The MIC5020 can control MOSFETs that switch voltages greater than 50V.

A rising or falling edge on the input results in a current source or sink pulse on the gate output. This output current pulse can turn on or off a 2000pF MOSFET in approximately 175ns. The MIC5020 then supplies a limited current (< 2mA), if necessary, to maintain the output state.

An overcurrent comparator with a trip voltage of 50mV makes the MIC5020 ideal for use with a current sensing MOSFET. An external low value resistor may be used instead of a sensing MOSFET for more precise overcurrent control. An optional external capacitor connected to the C<sub>T</sub> pin may be used to control the current shutdown duty cycle from 20% to < 1%. A duty cycle from 20% to about 75% is possible with an optional pull-up resistor from C<sub>T</sub> to V<sub>DD</sub>. An open collector output provides a fault indication when the sense inputs are tripped.

The MIC5020 is available in 8-pin SOIC package.

*Other members of the MIC502x series include the MIC5021 high-side driver and the MIC5022 half-bridge driver with a cross-conduction interlock.*

### Features

- 11V to 50V operation
- 175ns rise/fall time driving 2000pF
- TTL compatible input with internal pull-down resistor
- Overcurrent limit
- Fault output indication
- Gate to source protection
- Compatible with current sensing MOSFETs

### Applications

- Lamp control
- Heater control
- Motor control
- Solenoid switching
- Switch-mode power supplies
- Circuit breaker

### Ordering Information

Part Number		Temperature Range	Package
Standard	Pb-Free		
MIC5020BM	MIC5020YM	-40°C to +85°C	8-pin SOIC

### Typical Application

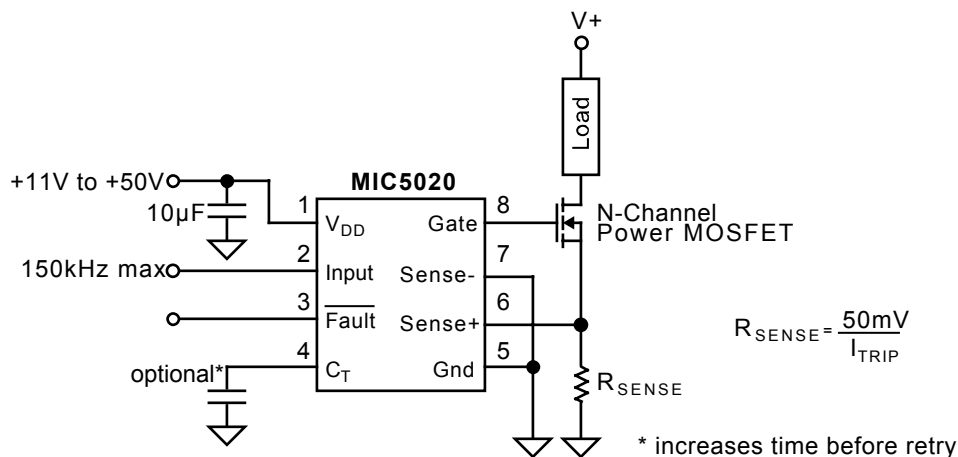

**Low-Side Driver with Overcurrent Trip and Retry**

## Pin Configuration

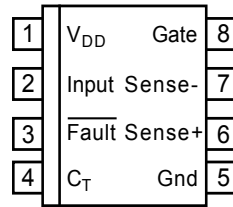

SOIC Package  
(M)

## Block Diagram

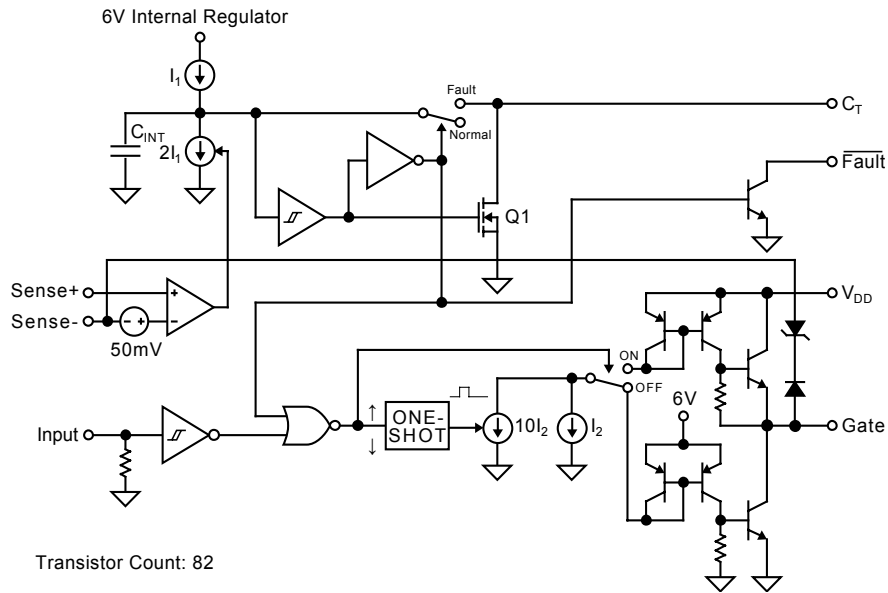

## Pin Description

Pin Number	Pin Name	Pin Function
1	$V_{DD}$	Supply: +11V to +50V. Decouple with $\geq 10\mu\text{F}$ capacitor.
2	Input	TTL Compatible Input: Logic high turns the external MOSFET on. An internal pull-down returns an open pin to logic low.
3	$\overline{\text{Fault}}$	Overcurrent Fault Indicator: When the sense voltage exceeds threshold, open collector output is open circuit for $5\mu\text{s}$ ( $t_{G(\text{ON})}$ ), then pulled low for $t_{G(\text{OFF})}$ . $t_{G(\text{OFF})}$ is adjustable from $C_T$ .
4	$C_T$	Retry Timing Capacitor: Controls the off time ( $t_{G(\text{OFF})}$ ) of the overcurrent retry cycle. (Duty cycle adjustment.) <ul style="list-style-type: none"> <li>• Open = 20% duty cycle.</li> <li>• Capacitor to Ground = approx. 20% to &lt;1% duty cycle.</li> <li>• Pull-Up resistor = approx. 20% to approx. 75% duty cycle.</li> <li>• Ground = maintained shutdown upon overcurrent condition.</li> </ul>
5	Gnd	Circuit Ground
6	Sense +	Current Sense Comparator (+) Input: Connect to high side of sense resistor or current sensing MOSFET sense lead. A built-in offset in conjunction with $R_{\text{SENSE}}$ sets the load overcurrent trip point.
7	Sense -	Current Sense Comparator (-) Input: Connect to the low side of the sense resistor (usually power ground).
8	Gate	Gate Drive: Drives the gate of an external power MOSFET. Also limits $V_{GS}$ to 15V max. to prevent Gate to Source damage. Will sink and source current.

**Absolute Maximum Ratings**

Supply Voltage ( $V_{DD}$ ).....	+55V
Input Voltage .....	-0.5V to +15V
Sense Differential Voltage .....	$\pm 6.5V$
Sense + or Sense - to Gnd.....	-0.5V to +50V
Fault Voltage .....	+50V
Current into $\overline{\text{Fault}}$ .....	50mA
Timer Voltage ( $C_T$ ).....	+5.5V

**Operating Ratings**

Supply Voltage ( $V_{DD}$ ).....	+11V to +50V
Temperature Range SOIC .....	-40°C to +85°C

**Electrical Characteristics**

$T_A = 25^\circ\text{C}$ , Gnd = 0V,  $V_{DD} = 12V$ , Sense +,- = 0V, Fault = Open,  $C_T = \text{Open}$ , Gate  $C_L = 1500\text{pF}$  unless otherwise specified

Symbol	Parameter	Condition	Min	Typ	Max	Units
	D.C. Supply Current	$V_{DD} = 12V$ , Input = 0V		0.8	2	mA
		$V_{DD} = 50V$ , Input = 0V		2	10	mA
		$V_{DD} = 12V$ , Input = 5V		0.8	2	mA
		$V_{DD} = 50V$ , Input = 5V		4	25	mA
	Input Threshold		0.8	1.4	2.0	V
	Input Hysteresis			0.1		V
	Input Pull-Down Current	Input = 5V	10	20	40	$\mu\text{A}$
	Fault Output Saturation Voltage	Fault Current = 1.6mA <b>Note 1</b>		0.15	0.4	V
	Fault Output Leakage	Fault = 50V	-1	0.01	+1	$\mu\text{A}$
	Current Limit Threshold	<b>Note 2</b>	30	50	70	mV
	Gate On Voltage	$V_{DD} = 12V$	10	11		V
		$V_{DD} = 50V$	14	15	18	V
$t_{G(ON)}$	Gate On Time, Fixed	Sense Differential > 70mV	2	5	10	$\mu\text{s}$
$t_{G(OFF)}$	Gate Off Time, Adjustable	Sense Differential > 70mV, $C_T = 0\text{pF}$	10	20	50	$\mu\text{s}$
$t_{DLH}$	Gate Turn-On Delay	<b>Note 3</b>		400	800	ns
$t_R$	Gate Rise Time	<b>Note 4</b>		700	1500	ns
$t_{DLH}$	Gate Turn-Off Delay	<b>Note 5</b>		900	1500	ns
$t_F$	Gate Fall Time	<b>Note 6</b>		500	1500	ns
$f_{max}$	Maximum Operating Frequency	<b>Note 7</b>	100	150		kHz

**Note 1** Voltage remains low for time affected by  $C_T$ .

**Note 2** When using sense MOSFETs, it is recommended that  $R_{SENSE} < 50\Omega$ . Higher values may affect the sense MOSFET's current transfer ratio.

**Note 3** Input switched from 0.8V (TTL low) to 2.0V (TTL high), time for Gate transition from 0V to 2V.

**Note 4** Input switched from 0.8V (TTL low) to 2.0V (TTL high), time for Gate transition from 2V to 10V.

**Note 5** Input switched from 2.0V (TTL high) to 0.8V (TTL low), time for Gate transition from 11V (Gate ON voltage) to 10V.

**Note 6** Input switched from 2.0V (TTL high) to 0.8V (TTL low), time for Gate transition from 10V from 2V.

**Note 7** Frequency where gate on voltage reduces to 10V with 50% input duty cycle.

# Typical Characteristics

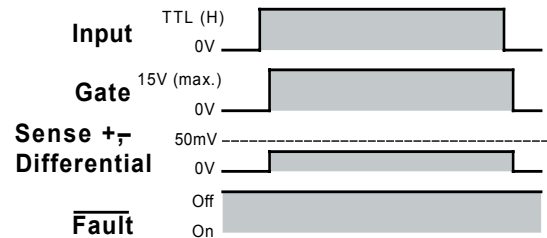
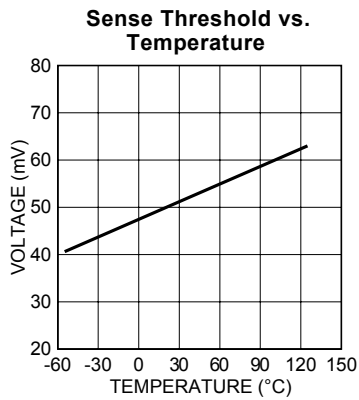
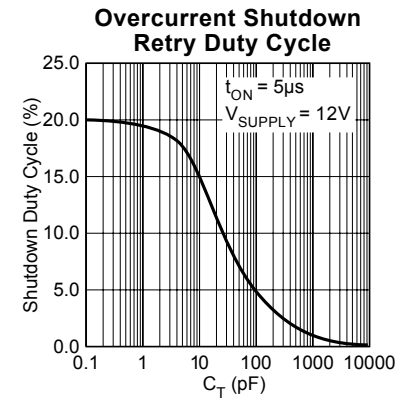
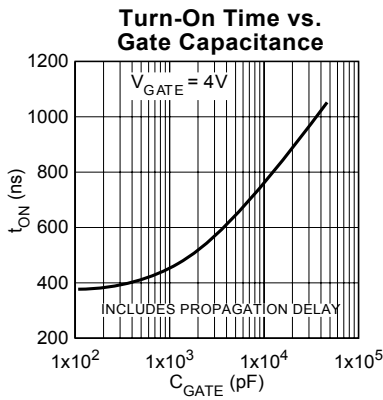
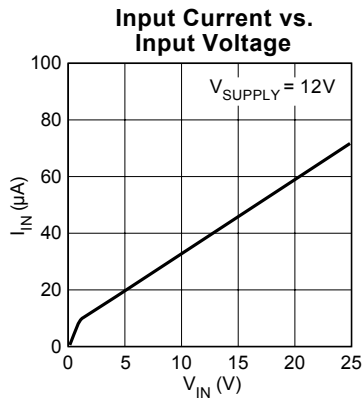
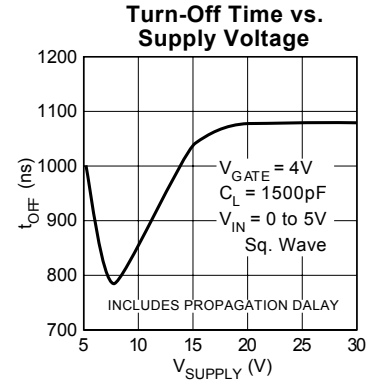
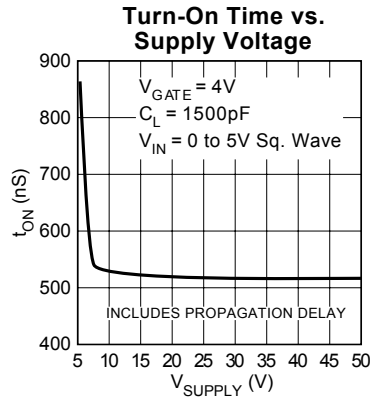
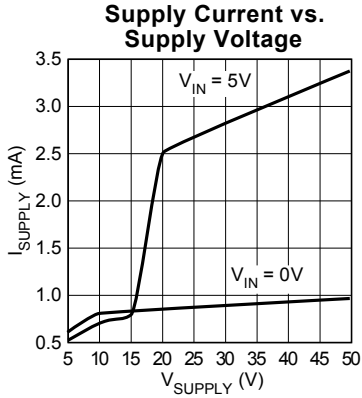

Timing Diagram 1. Normal Operation

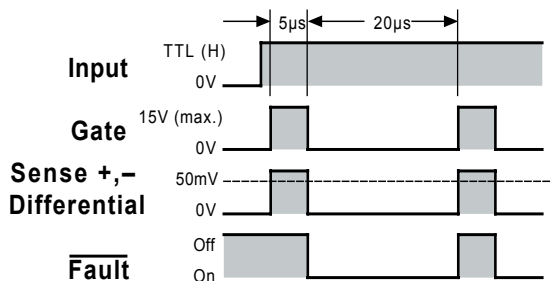

Timing Diagram 2. Fault Condition,  $C_T = Open$

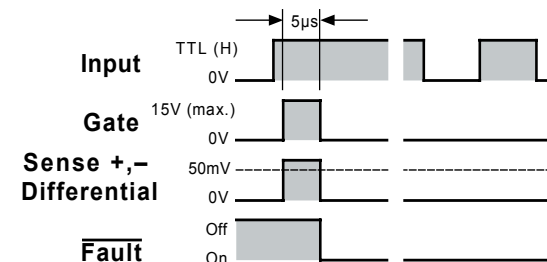

Timing Diagram 3. Fault Condition,  $C_T = Grounded$

## Functional Description

Refer to the MIC5020 block diagram.

### Input

A signal greater than 1.4V (nominal) applied to the MIC5020 INPUT causes gate enhancement on an external MOSFET turning the external MOSFET on.

An internal pull-down resistor insures that an open INPUT remains low, keeping the external MOSFET turned off.

### Gate Output

Rapid rise and fall times on the GATE output are possible because each input state change triggers a one-shot which activates a high-value current sink ( $10I_2$ ) for a short time. This draws a high current through a current mirror circuit causing the output transistors to quickly charge or discharge the external MOSFET's gate.

A second current sink continuously draws the lower value of current used to maintain the gate voltage for the selected state.

An internal 15V Zener diode protects the external MOSFET by limiting the gate output voltage when  $V_{DD}$  is connected to higher voltages.

### Overcurrent Limiting

Current source  $I_1$  charges  $C_{INT}$  upon power up. An optional external capacitor connected to  $C_T$  is discharged through

MOSFET Q1.

A fault condition ( $> 50\text{mV}$  from SENSE + to SENSE –) causes the overcurrent comparator to enable current sink  $2I_1$  which overcomes current source  $I_1$  to discharge  $C_{INT}$  in a short time. When  $C_{INT}$  is discharged, the INPUT is disabled, which turns off the GATE output; the FAULT output is enabled; and  $C_{INT}$  and  $C_T$  are ready to be charged.

When the GATE output turns the MOSFET off, the overcurrent signal is removed from the sense inputs which deactivates current sink  $2I_1$ . This allows  $C_{INT}$  and the optional capacitor connected to  $C_T$  to recharge. A Schmitt trigger delays the retry while the capacitor(s) recharge. Retry delay is increased by connecting a capacitor to  $C_T$  (optional).

The retry cycle will continue until the the fault is removed or the input is changed to TTL low.

If  $C_T$  is connected to ground, the circuit will not retry upon a fault condition.

### Fault Output

The FAULT output is an open collector transistor. FAULT is active at approximately the same time the output is disabled by a fault condition ( $5\mu\text{s}$  after an overcurrent condition is sensed). The FAULT output is open circuit (off) during each successive retry ( $5\mu\text{s}$ ).

## Applications Information

The MIC5020 MOSFET driver is intended for low-side switching applications where higher supply voltage, overcurrent sensing, and moderate speed are required.

### Supply Voltage

A feature of the MIC5020 is that its supply voltage rating of up to 50V is higher than many other low-side drivers.

The minimum supply voltage required to fully enhance an N-channel MOSFET is 11V.

A lower supply voltage may be used with logic level MOSFETs. Approximately 6V is needed to provide 5V of gate enhancement.

### Low-Side Switch Circuit Advantages

A moderate-speed low-side driver is generally much faster than a comparable high-side driver. The MIC5020 can provide the gate drive switching times and low propagation delay times that are necessary for high-frequency high-efficiency circuit operation in PWM (pulse width modulation) designs used for motor control, SMPS (switch mode power supply) and heating element control. Switched loads (on/off) can benefit from the MIC5020's fast switching times by allowing use of MOSFETs with smaller safe operating areas. (Larger MOSFETs are often required when using slower drivers.)

### Overcurrent Limiting

A 50mV comparator is provided for current sensing. The low level trip point minimizes  $I^2R$  losses when power resistors are used for current sensing. Flexibility in choosing drain or source side sensing is provided by access to both SENSE +

and SENSE – comparator inputs.

The adjustable retry feature can be used to handle loads with high initial currents, such as lamps, motors, or heating elements and can be adjusted from the  $C_T$  connection.

$C_T$  to ground causes maintained gate drive shutdown following overcurrent detection.

$C_T$  open, or through a capacitor to ground, causes automatic retry. The default duty cycle ( $C_T$  open) is approximately 20%. Refer to the electrical characteristics when selecting a capacitor for a reduced duty cycle.

$C_T$  through a pull-up resistor to  $V_{DD}$  increases the duty cycle. *Increasing the duty cycle increases the power dissipation in the load and MOSFET.* Circuits may become unstable at a duty cycles of about 75% or higher, depending on the conditions. *Caution: The MIC5020 may be damaged if the voltage on  $C_T$  exceeds the absolute maximum rating.*

An overcurrent condition is externally signaled by an open collector (FAULT) output.

The MIC5020 may be used without current sensing by connecting SENSE + and SENSE – to ground.

### Current Sense Resistors

Lead length can be significant when using low value ( $< 1\Omega$ ) resistors for current sensing. Errors caused by lead length can be avoided by using four-terminal current sensing resistors. Four-terminal resistors are available from several manufacturers.

**Lamp Driver Application**

Incandescent lamps have a high inrush current (low resistance) when turned on. The MIC5020 can perform a “soft start” by pulsing the MOSFET (overcurrent condition) until the filament is warm enough for its current to decrease (resistance increases). The sense resistor is selected so the voltage across the sense resistor drops below the sense threshold (50mV) as the filament becomes warm. The MOSFET is no longer pulsed to limit current and the lamp turns completely on.

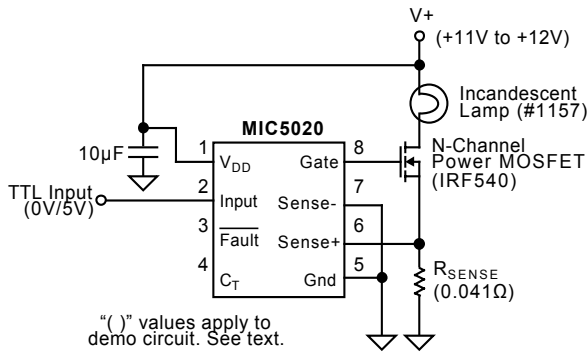

**Figure 1. Lamp Driver with Current Sensing**

A lamp may not fully turn on if the filament does not heat up adequately. Changing the duty cycle, sense resistor, or both to match the filament characteristics can correct the problem.

Soft start can be demonstrated using a #1157 dual-filament automotive lamp. The value of  $R_S$  shown in figure 1 allows for soft start of the higher-resistance filament (measures approx. 2.1Ω cold or 21Ω hot).

**Solenoid Driver Application**

The MIC5020 can be directly powered by the control voltage supply in typical 11Vdc through 50Vdc control applications. Current sensing has been omitted as an example.

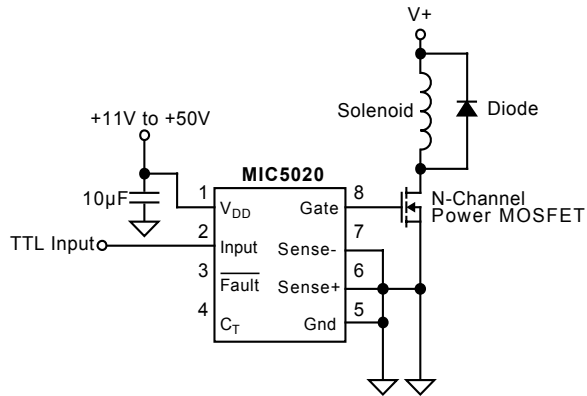

**Figure 2. Solenoid Driver, Without Current Sensing**

A diode across the load protects the MOSFET from the voltage spike generated by the inductive load upon MOSFET turn off. The peak forward current rating of the diode should be greater than the load current.

**Current Sensing MOSFET Application**

A current sensing MOSFET allows current sensing without adding additional resistance to the power switching circuit.

A current sensing MOSFET has two source connections: a “power source” for power switching and a “current source” for current sensing. The current from the current source is approximately proportional to the current through the power source, but much smaller. A current sensing ratio ( $I_{SOURCE}/I_{SENSE}$ ) is provided by the MOSFET manufacturer.

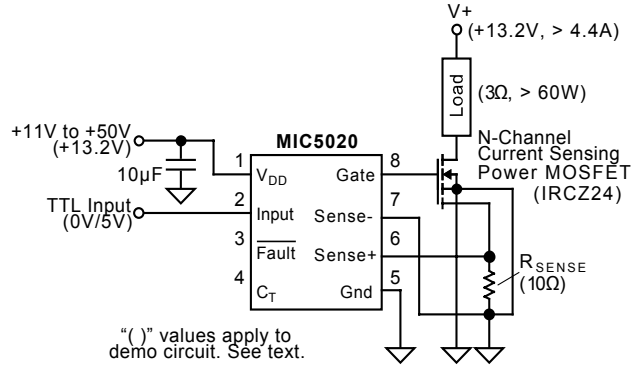

**Figure 3. Using a Current Sensing MOSFET**

The MOSFET current source is used to develop a voltage across a sense resistor. This voltage is monitored by the MIC5020 (SENSE + and SENSE – pins) to identify an over-current condition.

The value of the sense resistor can be estimated with:

$$R_{SENSE} = (r V_{TRIP} R_{DS(ON)}) / (I_{LOAD} R_{DS(ON)} - V_{TRIP})$$

where:

- $R_{SENSE}$  = external “sense” resistor
- $V_{TRIP}$  = 50mV (0.050V) for the MIC5020
- $r$  = manufacturer’s current sense ratio: ( $I_{SOURCE}/I_{SENSE}$ )
- $R_{DS(ON)}$  = manufacturer’s power source on resistance
- $I_{LOAD}$  = load current (power source current)

The drain to source voltage under different fault conditions affects the behavior of the MOSFET current source; that is, the current source will respond differently to a slight over-current condition ( $V_{DS(ON)}$  very small) than to a short circuit (where  $V_{DS(ON)}$  is approximately equal to the supply voltage).

Adjustment of the sense resistor value by experiment starting from the above formula will provide the quickest selection of  $R_{SENSE}$ .

Refer to manufacture’s data sheets and application notes for detailed information on current sensing MOSFET characteristics.

Figure 3 includes values which can be used to demonstrate circuit operation. The IRCZ24 MOSFET has a typical sense ratio of 780 and a  $R_{DS(ON)}$  of 0.10Ω. A large 3Ω wirewound load resistor will cause inductive spikes which should be suppressed using a diode (using the same configuration as figure 2).



**Faster MOSFET Switching**

The MIC5020's GATE current can be multiplied using a pair of bipolar transistors to permit faster charging and discharging of the external MOSFET's gate.

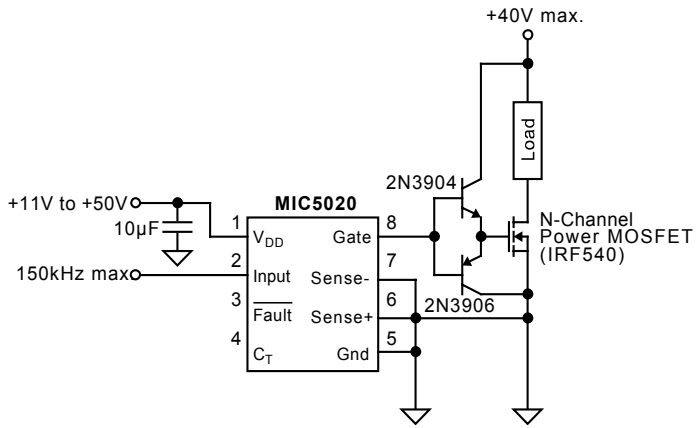

**Figure 4. Faster MOSFET Switching Circuit**

NPN and PNP transistors are used to respectively charge and discharge the MOSFET gate. The MIC5020 gate current is multiplied by the transistor  $\beta$ .

The switched circuit voltage can be increased above 40V by selecting transistors with higher ratings.

**Remote Overcurrent Limiting Reset**

In circuit breaker applications where the MIC5020 maintains an off condition after an overcurrent condition is sensed, the  $C_T$  pin can be used to reset the MIC5020.

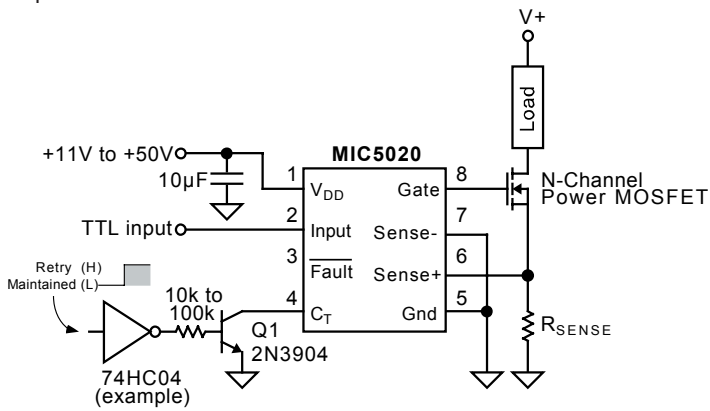

**Figure 5. Remote Control Circuit**

Switching Q1 on pulls  $C_T$  low which keeps the MIC5020 GATE output off when an overcurrent is sensed. Switching Q1 off causes  $C_T$  to appear open. The MIC5020 retries in about 20 $\mu$ s and continues to retry until the overcurrent condition is removed.

For test purposes, a 680 $\Omega$  load resistor and 3 $\Omega$  sense resistor will produce an overcurrent condition when the load's supply (V+) is approximately 12V or greater.

**Low-Temperature Operation**

As the temperature of the MIC5020AJB (extended temperature range version—no longer available) approaches  $-55^\circ\text{C}$ , the driver's off-state, gate-output offset from ground increases. If the operating environment of the MIC5020AJB includes low temperatures ( $-40^\circ\text{C}$  to  $-55^\circ\text{C}$ ), add an external 2.2M $\Omega$  resistor as shown in Figures 6a or 6b. This assures that the driver's gate-to-source voltage is far below the external MOSFET's gate threshold voltage, forcing the MOSFET fully off.

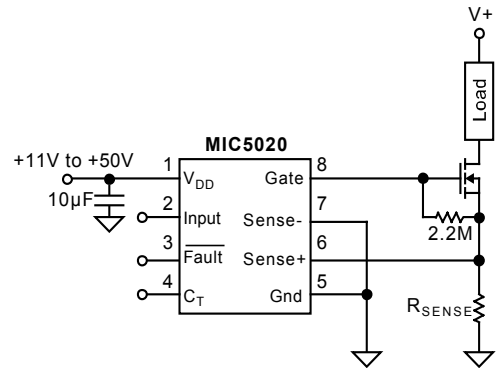

**Figure 6a. Gate-to-Source Pull Down**

The gate-to-source configuration (refer to Figure 6a) is appropriate for resistive and inductive loads. This also causes the smallest decrease in gate output voltage.

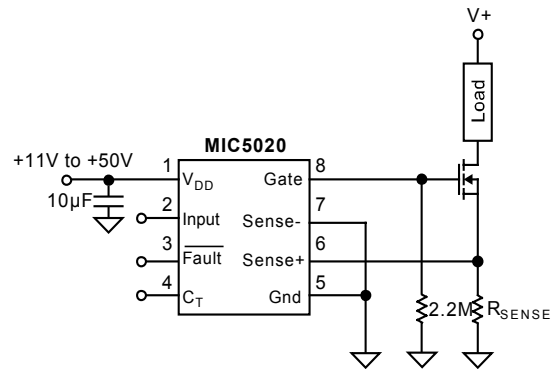

**Figure 6b. Gate-to-Ground Pull Down**

The gate-to-ground configuration (refer to Figure 6b) is appropriate for resistive, inductive, or capacitive loads. This configuration will decrease the gate output voltage slightly more than the circuit shown in Figure 6a.

## Package Information

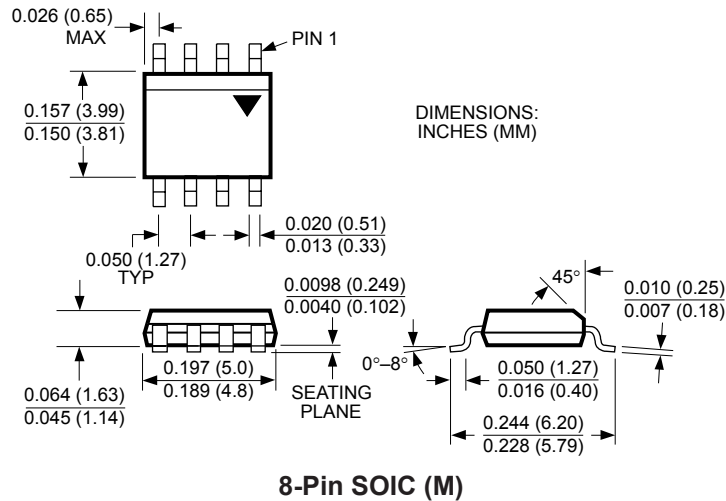

**MICREL INC. 2180 FORTUNE DRIVE SAN JOSE, CA 95131 USA**  
 TEL + 1 (408) 944-0800 FAX + 1 (408) 474-1000 WEB <http://www.micrel.com>

This information furnished by Micrel in this data sheet is believed to be accurate and reliable. However no responsibility is assumed by Micrel for its use. Micrel reserves the right to change circuitry and specifications at any time without notification to the customer.

Micrel Products are not designed or authorized for use as components in life support appliances, devices or systems where malfunction of a product can reasonably be expected to result in personal injury. Life support devices or systems are devices or systems that (a) are intended for surgical implant into the body or (b) support or sustain life, and whose failure to perform can be reasonably expected to result in a significant injury to the user. A Purchaser's use or sale of Micrel Products for use in life support appliances, devices or systems is a Purchaser's own risk and Purchaser agrees to fully indemnify Micrel for any damages resulting from such use or sale.

© 1998 Micrel, Inc.